

PSensor SSI 31 2xPIR 8DP DG

D4i motion and light sensor for street lighting

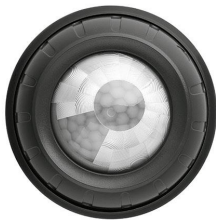

Product description

- _ Monitoring of ambient light and occupancy detection
- _ Integrated temperature measurement
- _ 2 x PIR Sensor built-in enabling extended features like detecting objects with side orientation
- _ Low energy consumption over DALI-2 bus supply
- _ Ready for Zhaga Book 18 Ed. 3 receptacle for easy and flexible installation to luminaire
- _ Rectangular detection area ideal for street applications
- _ Pressure equalizing membrane built-in
- _ D4i approved and fully compatible with DALI Part 351 including MB201
- _ Lifetime up to 100,000 h at $t_c = 60^\circ\text{C}$
- _ 8 years guarantee in combination with Tridonic LED driver PRE3 (other case 5 years guarantee) (conditions at <https://www.tridonic.com/manufacture-guarantee-conditions>)

Housing properties

- _ Casing: Dark grey (RAL 7040)
- _ Type of protection up to IP66
- _ Impact protection degree IK08 (lens excluded)

Benefits

- _ Innovative: First DALI-2 asymmetric motion sensor based on Zhaga receptacle
- _ Flexible: Individual adjustment of parameters with configuration software
- _ Reliable: Highest outdoor requirements tested

Typical applications

- _ Rectangular detection area ideal for street application at 4 to 8 m mounting height

Website

<http://www.tridonic.com/28002642>



PSensor SSI 31 2xPIR 8DP DG

D4i motion and light sensor for street lighting

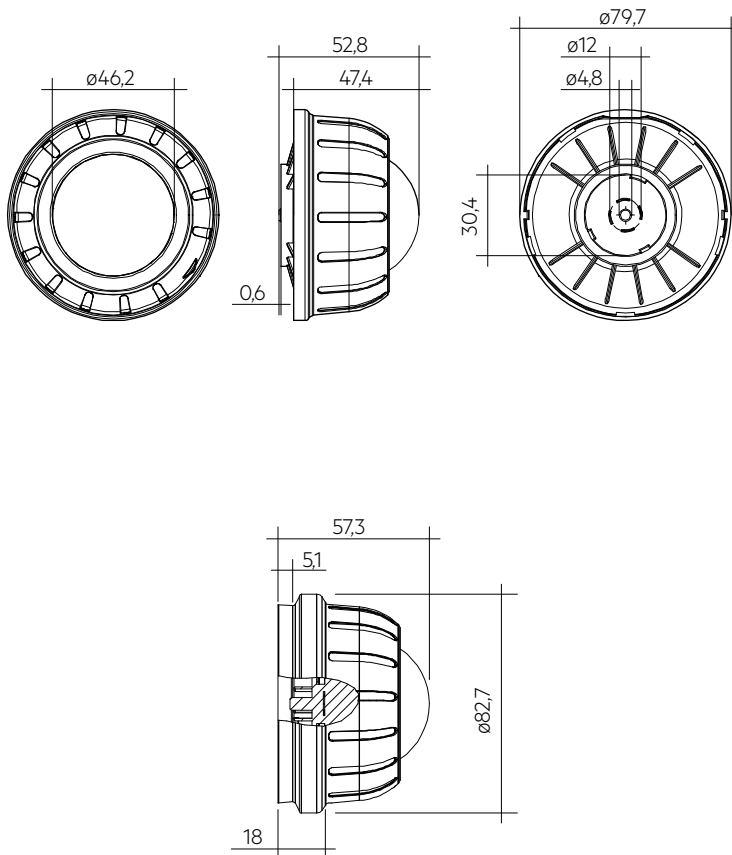

Dimensions with dust and dirt protection

Ordering data

Type	Article number	Suitable for	Packaging, carton	Weight per pc.
PSensor SSI 31 2xPIR 8DP DG	28002642	Street & Road lighting	20 pc(s).	0.122 kg

Technical data

Sensor type	Movement and light sensor, including 2 x PIR sensors
Supply via	DALI
Supply voltage ^①	9.5 – 22.5 V
Current consumption (no LED)	max. 7 mA
Current consumption (with LED)	max. 8.1 mA
Starting time	30 s
Supported operating modes	0 or 128 (default)
Mounting height	4 – 8 m
Mounting hole	acc. to Zhaga Book 18 Ed. 3
Type of installation ^②	Zhaga Book 18 Ed. 3 socket
Presence detection area at 6 m height	26 m x 12 m = 312 m ²
Detection angle for light measurement	76°
Detection range for light measurement ^③	1 – 4,000 lx
Temperature sensor built-in	Yes
Min. temperature difference between ambient temperature and detected object	± 4 °C
Ambient temperature ta ^④	-25 ... +50 °C
tc point	60 °C
Storage temperature ts	-25 ... +60 °C
Humidity	0 ... 90 %
Dimensions Ø x H	Ø 79.7 x 52.8 mm
Diameter with dust and dirt protection	Ø 82.7 mm
Height with dust and dirt protection	57.3 mm
Housing material body	Lexan 923
Housing material lens	HDPE
Housing ^⑤	Dark grey (RAL 7040)
Housing colour lens	Transparent white
Type of protection	IP66
Impact protection degree ^⑥	IK08
Lifetime	100,000 h
Guarantee (conditions at www.tridonic.com)	5 Year(s)

Approval marks**Standards**

EN 61347-2-11, EN 55015, EN 61000-3-2, EN 61000-3-3, EN 61547, EN 62386-101, EN 62386-103, EN 62386-303, EN 62386-304, EMC directive 2014/30/EC

① Uin acc. IEC 62386-101.

② Device must be installed on the bottom side of the luminaire.

③ The measured value at the sensor head corresponds to 20 – 90 % of the lux value measured on the surface located below the sensor.

④ Correct sensor operation can not be guaranteed if operated outside this ta window.

⑤ Technical colour specification = 7040, optical colour specification = 9007.

⑥ It is essential to mount the plug connection (AZU Z18 Set) and sensor correctly to achieve the full IK rating. These impact protection degree does not apply to the lens.

ACU Z18 Set

Accessory

**Product description**

- _ Set consisting of receptacle, lock washer and mounting nut (ACU Z18 REP 4PIN)
- _ Designed for street lighting control
- _ Compliant with Zhaga Book 18 Ed. 3
- _ Optional IP66 with sealing cap (ACU Z18 CAP IP66)
- _ UL UV-f1 rated for outdoor use
- _ Impact protection degree IK09
- _ For more details see data sheet ACU Z18 Set

Housing properties

- _ Casing receptacle: PBT
- _ Type of protection IP20

Interfaces

- _ Supplies Zhaga Book 18 Ed. 3 contact system

Website

<http://www.tridonic.com/28003209>

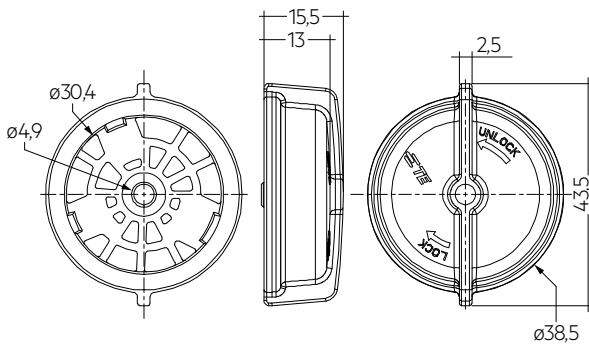
**Ordering data**

Type	Article number	Packaging, bag	Weight per pc.
ACU Z18 REP 4PIN	28003209	100 pieces	0.008 kg
ACU Z18 CAP IP66	28003208	100 pieces	0.020 kg

Approval marks

1. Standards

EN/IEC 61347-2-11:2001
 EN 55015:2013
 EN 61000-3-2:2014 Part 3-2
 EN 61000-3-3:2013 Part 3-3
 EN 61547:2009
 EN 62386-101 Ed.2
 EN 62386-103 Ed.1
 EN 62386-303
 EN 62386-304
 EMC directive 2014/30/EC

1.1 DALI note



Sensor only applicable for DALI-2 installations according to EN 62386-101 Ed.2.

1.2 D4i note

D4i luminaire-mounted control devices (part 351) = Type B

1.3 Glow wire test

according to EN 61347-1 passed with 750 °C.

2. Common

The Tridonic PSensor SSI 31 2xPIR 8DP DG is one of the first motion sensor developed especially to fit perfectly in Urban Outdoor Applications. With its 2 PIR technology elements the PSensor allows a wide detection range of typical streets and supporting a coverage area at 8 m height of up to 35 m x 16 m = 560 m². Furthermore the sensor with its 2 PIR elements provide a three area detection, supporting side orientation and heatmapping. An integrated temperature measurement allowing deeper analysis of ambient temperature surrounding the luminaire. The innovative platform design of the sensor enables easy plug and play by supporting the Zhaga Book 18 Ed. 3. The flexible mounting height from 4 – 8 m allows in addition a huge variation of use-cases to be covered. Next to its robust design and long lifetime the IP66 rating complement an excellent protection against harsh outdoor environment.

3. Installation

- The PSensor must not be connected to mains. It is supplied directly via the DALI power supply.
- DALI is not SELV. The installation instructions for mains voltage therefore apply.
- Please ensure that the detection ranges of the sensors do not overlap. This may have influence to the light measurement.
- When installed at another height than the recommended installation height, the presence sensor might show different characteristics. When mounted at a higher level, the sensitivity is reduced. If mounted at a lower level, the range is reduced.
- Heat sources located in the detection zone may cause incorrect presence detection.
- The triangular sign indicates the direction to the street (Zhaga y axis) when the sensor is locked in place.
- PSensor is developed to cover the mentioned detection area. Depending on the environment, sensor may also detect objects located outside the mentioned detection area.
- Correct sensor operation can not be guaranteed if operated outside his ta window.
- Make sure the sensor is mounted correctly and locked in place.
- Motions of the pole may trigger the sensor.
- The detection range can be reduced if the sensor is mounted too close to the pole.
- Sensor may be triggered by nearby trees, branches or smaller animals.
- Min. temperature difference between ambient temperature and detected object is $\pm 4^{\circ}\text{C}$. Objects inside this window may not be detected by the sensor.
- Avoid direct illumination of the light source on the sensor including housing.

3.1 Wiring

For EN 62386-101 Ed. 2 systems:

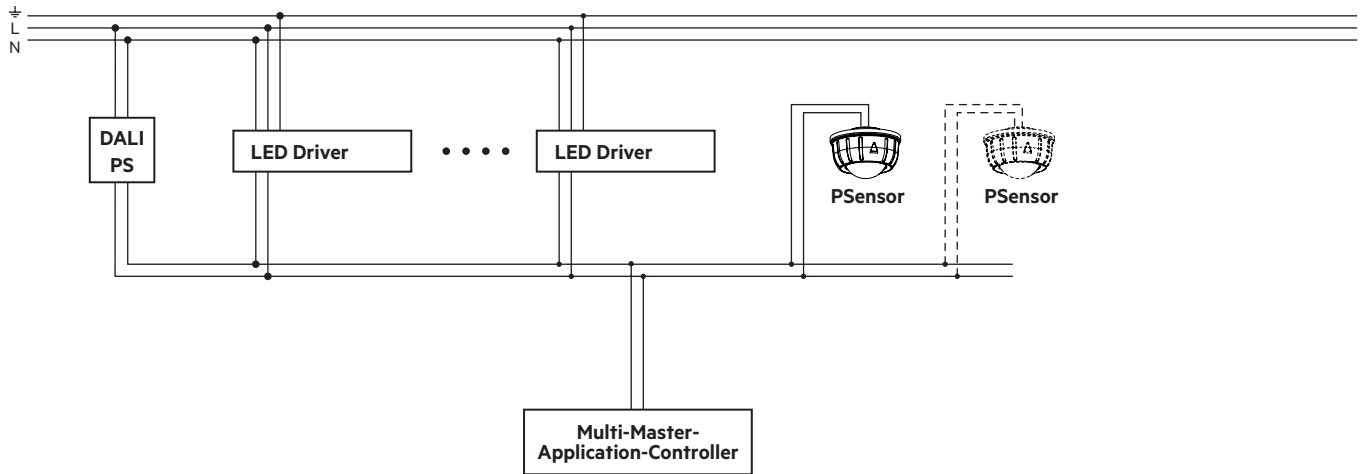

OTD system overview:

The sensor is optimized to be used in combination with Tridonic RFNode (Multi-Master) and the Streetlight LED driver PRE3 with internal power supply. Following illustration visualizes the wiring of the components inside the luminaire.

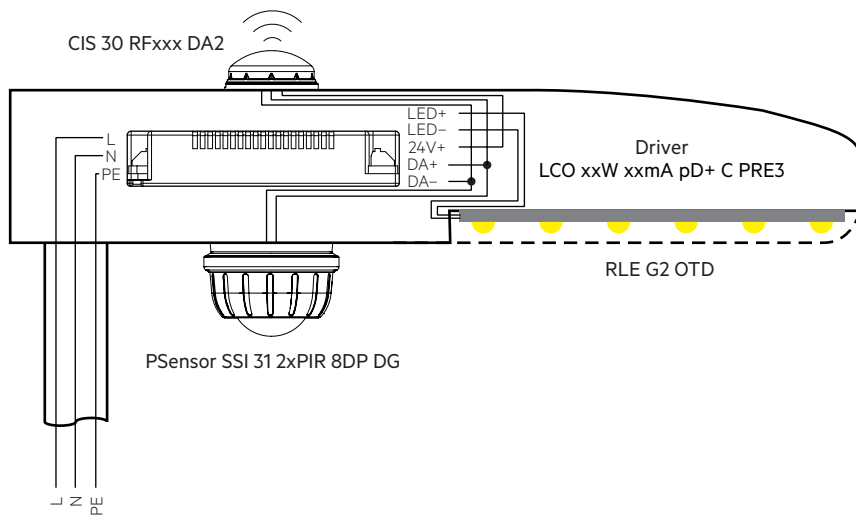

The sensor supports the Zhaga connectivity standard for Plug and Play luminaire extensions. This allows a toolless and flexible integration in luminaires. The connection interface is designed according to Zhaga Book 18 Ed. 3.

Pin assignment PSensor

Pins	Assignment
Pin 1	Not connected
Pin 2*	Negative Pole of DALI (DA-)
Pin 3*	Positive Pole of DALI (DA+)
Pin 4	Not connected

* The polarity is not mandatory for function of the sensor, but is mentioned because the receptacle has to be designed according to Zhaga Book 18 Ed. 3 and inside the luminaire the polarity has to be wired correctly.

 The Zhaga connector pins mounted in the luminaire, have to follow the same pin assignment as described in Zhaga Book 18 Ed. 3!

3.2 Mounting instructions

Assembly visualization, see data sheet AZU Z18 Set too:

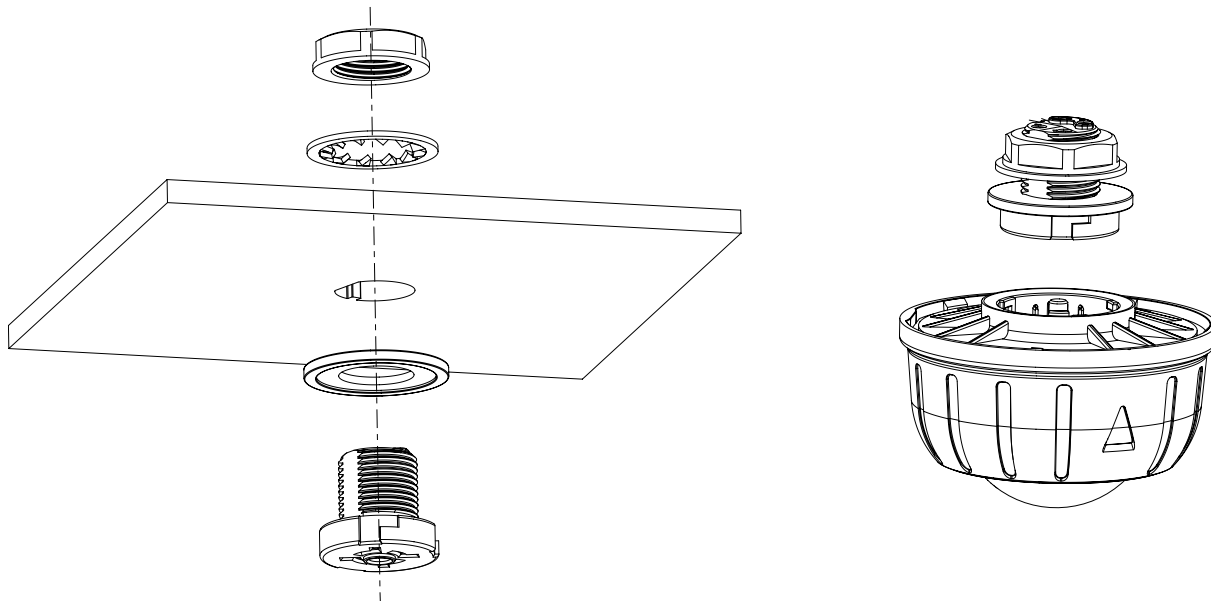

Zhaga Book 18 Ed. 3 axis description:

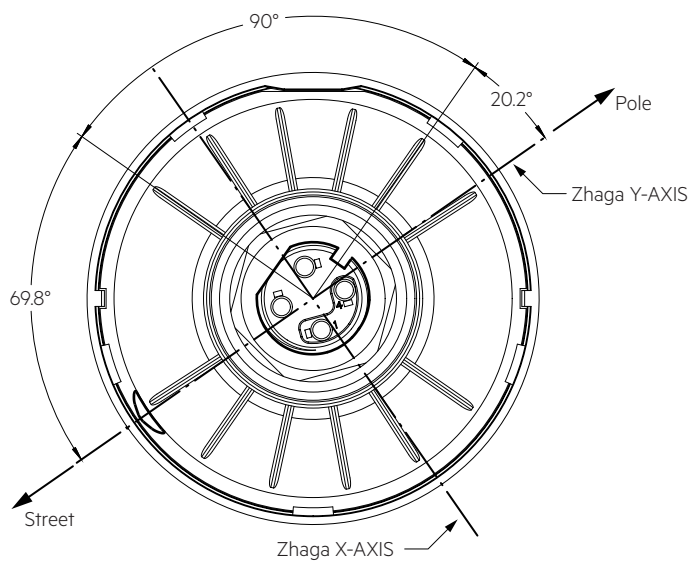

Installation on luminaire:

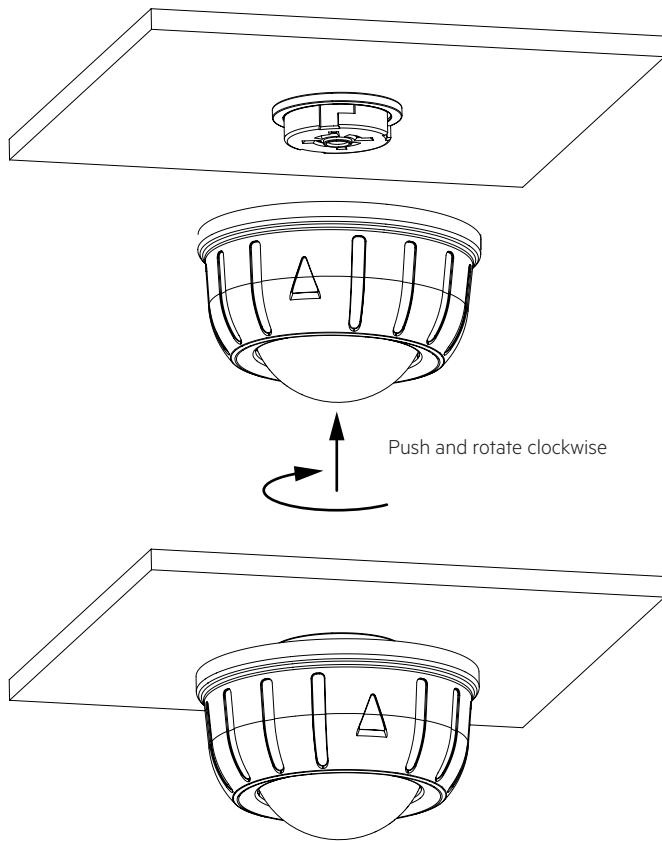

 The triangular sign indicates the direction to the street (Zhaga y axis) when the sensor is locked in place. The sensor must lock.

Make sure that the dust and dirt protection, is not bent, no foreign parts between the seal and the fixture housing are located and that the protection fits the fixture.

3.3 QR Code

On the bottom of the sensor an QR Code is located. The QR Code can be scanned with Tridonic Service App and will provide additional Information about the Sensors like e.g. Batch Number.

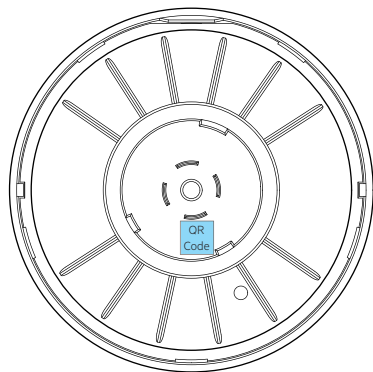



4. Sensor function

4.1 Motion detection

PSensor is designed to be used in urban street lighting application. The sensor lens is designed for 0 degrees tilt, parallel to the road surface. The motion sensor detects a moving object with different surface temperature compared to the background (mainly pedestrians). The PIR technology is used, covering a rectangular area (part of a street).

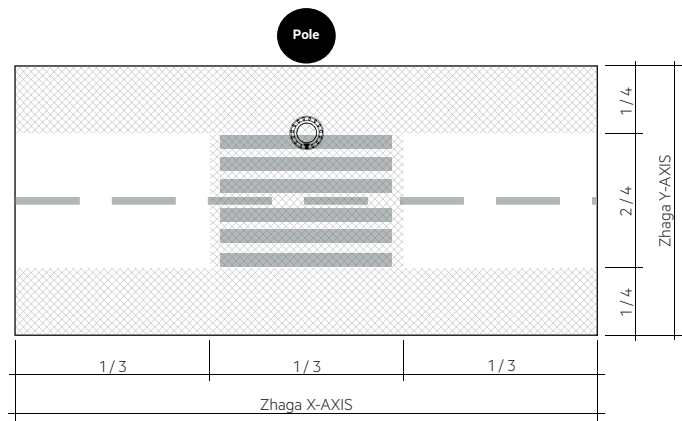
Overview of sensitivity areas:



 The full detection area is rectangular, the highlighted area is optimized for detection of pedestrians. The detection area is not sharp-edged but runs smoothly over the marked borders.

Sensitivity of the sensor can be matched via Application-Controller.

4.2 Motion detection area

The triangular sign indicates the direction to the street (Zhaga y axis) when the sensor is locked in place.

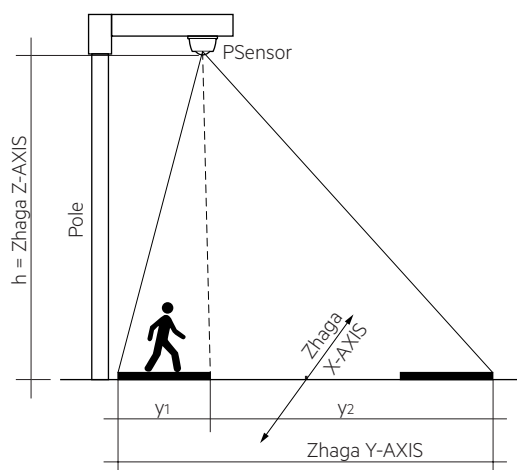

The detection range area y_1 can be reduced if the sensor is mounted too close to the pole.

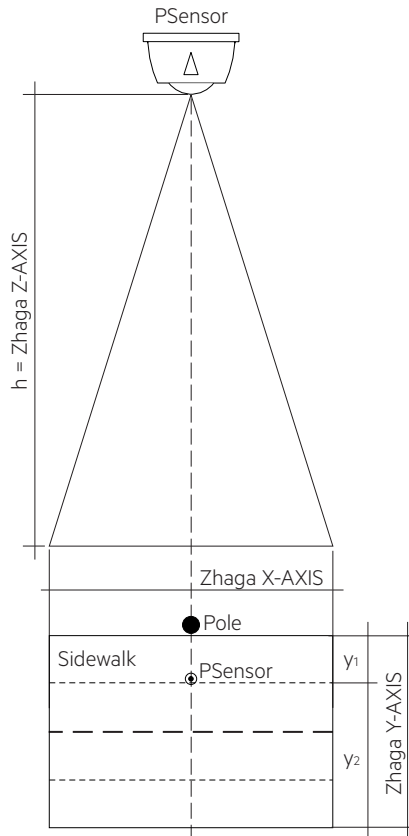

Height	Detection area				Covered area
	x	y	y ₁	y ₂	
4.0 m	17.0 m	8 m	2.0 m	6.0 m	136 m ²
4.5 m	19.3 m	9 m	2.3 m	6.8 m	173 m ²
5.0 m	21.5 m	10 m	2.5 m	7.5 m	215 m ²
5.5 m	23.8 m	11 m	2.8 m	8.3 m	261 m ²
6.0 m	26.0 m	12 m	3.0 m	9.0 m	312 m ²
6.5 m	28.3 m	13 m	3.3 m	9.8 m	367 m ²
7.0 m	30.5 m	14 m	3.5 m	10.5 m	427 m ²
7.5 m	32.8 m	15 m	3.8 m	11.3 m	491 m ²
8.0 m	35.0 m	16 m	4.0 m	12.0 m	560 m ²

4.3 Direction based presence detection

The 2 PIR technology allows direction based presence detection.

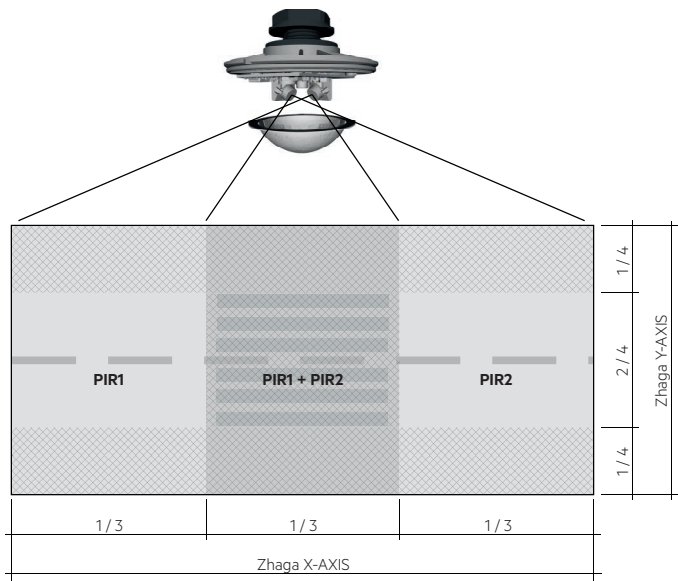

To be able to use this feature the right instance has to be queried and calculated by the Application-Controller.

Following table shows the instances and which values they provide.

DALI instances	
Instance number	Explanation
0	OR-conjunction of PIR 1 and PIR 2
1	PIR 1 only
2	PIR 2 only
3	Light sensor

4.3 Light measurement

The light measurement is detected in an angle of 76°.

The light sensor is located behind the sensor lens, for that reason, the sensor is not sufficient to be used for constant light control.

The triangular sign indicates the direction to the street (Zhaga y axis) when the sensor is locked in place.

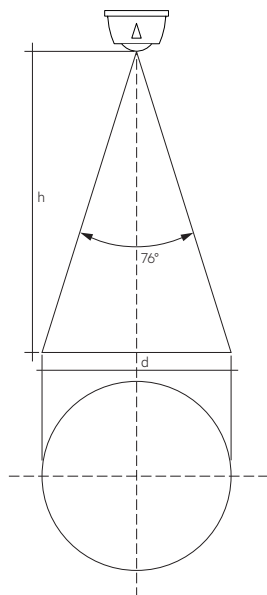

Height	Detection area	Covered area
h	d	-
4.0 m	6.2 m	31 m ²
4.5 m	7.0 m	39 m ²
5.0 m	7.8 m	48 m ²
5.5 m	8.6 m	58 m ²
6.0 m	9.4 m	69 m ²
6.5 m	10.2 m	81 m ²
7.0 m	10.9 m	94 m ²
7.5 m	11.7 m	108 m ²
8.0 m	12.5 m	123 m ²

4.3.1 Light value format

The default operating mode is 128.

In this mode the user is able to choose from fixed point and floating point values for the light measurement. The default setting are floating point values.

In addition to operation mode 128 also operating mode 0 is implemented.

In operating mode 0 the fixed point values are supported for the light measurement values.

Resolution for fixed point and floating point = 1/64 Lux

The measurement range is between 1 and 4,000 lx.

Measured at the sensor head.



To be able to measure values < 5 lx in an accurate way it is needed to set integration time of light sensor to 800 ms or more. 800 ms is the default value for this sensor.

For values > 5 lx integration time can be set below 800 ms.

4.4 Status LED

There is a LED built in to indicate different status information to the user.

Event	Blinking sequence	LED Color
DALI command „identify device“	500 ms on / 500 ms off for 10 s	Red
Powering the sensor	The LED in the sensor flashes for 5 s with a 500 ms pulse duration to signal the installer that the sensor is ready for use.	Green
Motion detection ^①	Default deactivated but can be activated by the application controller. If active, 1,000 ms on every time Motion is detected.	Red

Light measurement priority

^① By default, these blinking patterns are interrupted by the light measurement, because the light measurement has a higher priority.

This behavior can be changed via the application controller, i.e. it can be configured that the blinking patterns are carried out, regardless of an ongoing light measurement. Consequently, the accuracy of the light measurement will become worse, because the brightness of the LED distorts the measurement.

4.5 Temperature sensor

The sensor is typically located below a luminaire and almost no self heating appears the temperatures measured by the sensor are quite similar to the ambient temperature (ta).

The sensor stores the max., min. and mean value of all measurements.

5. Miscellaneous

5.1 Disposal of equipment



Return old devices in accordance with the WEEE directive to suitable recycling facilities.

5.2 Additional information

Additional technical information at www.tridonic.com → Technical Data

Guarantee conditions at www.tridonic.com → Services

Lifetime declarations are informative and represent no warranty claim.

No warranty if device was opened.